

# The TOOLSHED

NUMBER 78



SEPTEMBER 1993

A Journal of Tool Collecting published by CRAFTS of New Jersey

## Foreign Wooden Planes by Jack Whelan

Those of you who collect wooden planes seem to fall into one of two groups. If their attraction for you lies in their history, and in the biographies and the personal lives of their makers, you may find little of interest in planes made beyond the borders of America and England. These are most often unsigned, and historical data on their makers remains largely unexplored (although the recently formed Dutch tool society is working to rectify this for the Netherlands). My own principal interest is not in who made the plane, but in what it was intended to do, how it was used and how it was made.

If these aspects intrigue you, I can recommend closer attention to foreign planes. Different cultures have produced variations in the design of their planes that are interesting in their own right, and also (by showing alternate ways of accomplishing the same purpose) help to emphasize the true essentials of shaping and smoothing wood.

As one example, the wooden Jack plane that we are familiar with has a rear handle. We learn to keep pressure on its toe when starting a cut, and to transfer the pressure to its heel as the cut nears the far end. The left hand presses on the front of the stock at first, and the pressure is decreased or the left hand is removed as the cut finishes. The German plane used for the same purpose is of quite different shape (Figure 1). The left hand holds the horn grip at the toe, while the right provides the push from the rear. Both planes must provide the same sequence of pressure patterns during the cut, but the method of doing so is quite different. Our Jack handle, providing a handhold above the body of the plane, tends to direct the thrust on the blade downward, and there is no need for downward pressure on the toe once the cut is begun. The German right hand position provides thrust more in line with the stock, and the front horn is convenient to provide a bit of downward pressure,

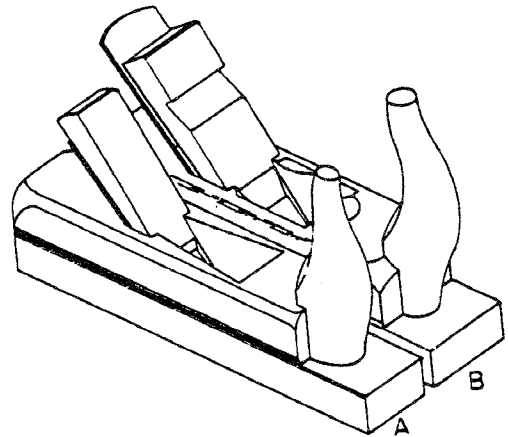

Figure 1. German scrub and smooth planes.

and to lift the toe at the end of the cut (more necessary with the shorter plane bodies they use).

*continued on page 4*

### CRAFTS DUES

**Is this your last *TOOLSHED*? If you received a dues reminder notice in July and have not yet paid your 1993-94 dues of \$10, it will be! Mail your \$10 check (payable to CRAFTS of New Jersey) to Helen Whelan, 38 Colony Ct, Murray Hill, NJ 07974.**

**September 12 - CRAFTS Picnic  
Brady Camp (see separate flyer)**

# CRAFTS of New Jersey

Collectors of Rare and Familiar Tools Society  
of New Jersey

President . . . . JOHN M. WHELAN, Murray Hill  
Vice President . . . JOSEPH G. HAUCK, Lebanon  
Secretary . . . . BARBARA FARNHAM, Stockton  
Treasurer . . . . . HELEN WHELAN, Murray Hill

The purpose of CRAFTS of New Jersey is to encourage interest in early trades and industries, and in the identification, study, preservation and exhibition of tools and implements used and made in New Jersey as an integral part of our heritage.

Membership in CRAFTS is open to anyone who shares the above interests. Annual dues per person or couple are ten dollars for the membership year of July 1 through June 30. Membership fees may be sent to the Treasurer: Helen Whelan, 38 Colony Court, Murray Hill, NJ 07974.

CRAFTS of NJ meets at the HOST Masonic Lodge, High Bridge. Take I-78 to Route 31 exit at Clinton. Go north on Rte. 31 two miles to second traffic light at the High Bridge exit. Turn right and go about half a mile to Dennis Ave. Turn left, then straight to the Masonic Lodge (on the left). Tailgate sales in the parking lot begin at 1 P.M.; meeting is at 2:00.

## THE TOOL SHED

Published five times a year for members of CRAFTS of New Jersey. Editor: Stuart Shippey, 251 Hillside Ave., Chatham, NJ 07928-1732. Assistant Editor: Herb Kean. Articles, especially about New Jersey tools and trades, are encouraged and may be sent to the editor. Send hand written or typed text, or ascii or *Word Perfect*® PC disk, or FAX to 201 301-9781.

## CRAFTS Calendar of Events

- Sept. 12 - CRAFTS Picnic at Pottersville, N.J.
- Sept. 25 - *TOOLSHED* and free ad deadline
- Nov. 7 - CRAFTS meeting at High Bridge, N.J.



A few hammers from Dan Comerford's June presentation

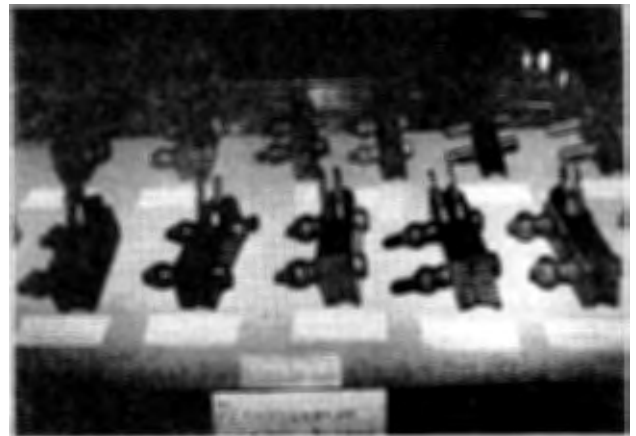

Bob Zarich's June display of Pennsylvania sash planes

## Definition of a Tool

Shown below is a definition of a tool as submitted by W. Andrew Worthington from Stoudsburg, Pa.

*Basically, a tool is an object that enables you to take advantage of the laws of physics and mechanics in such a way that you can seriously injure yourself.*

We would like to see your definition of a tool. Prizes will be awarded in the serious and whimsical categories. Who knows, maybe we can get Webster to change his mind.



## PRESIDENT'S CORNER

Once again the too-short summer is drawing to a close, and it's time to start the '93-'94 CRAFTS year. Membership is at an all-time high (407), but will fall well below that unless you all get your dues checks in. Don't wait too long: we plan a membership roster shortly and only paid-up members will be included.

As you may have noticed in the lists of new members that usually close this column, we are attracting members from well beyond the local area. The super job Stuart Shippey and Herb Kean are doing on the TOOL SHED produces a publication that is worth ten bucks of any tool buff's money, whether or not they can get to our meetings. Why not let some of your tool buddies in on the bargain? New members will help to keep your dues at the present rate.

Ken Vliet promises his usual great season-opener with the picnic at Brady camp (you will read about it in the enclosed flyer), and Don Kahn promises some good speakers for our regular meetings.

Mercer Museum in Doylestown is planning a tool session on November 13, and several CRAFTS members will be participating. Perhaps Herb Kean's column (in the next issue) on the Mercer will whet your appetite for a visit, and this might be a good day for it.

Welcome to new members Andrew Allena (Somerville); Jeffrey Baum (Glenwood Landing, NY); James Cascarano (Ossining, NY); Joe Casilli (Wappinger Falls, NY); David Crocco (Ridgewood); Andrea Filipone & William Welch (Morristown); Mr. & Mrs. R. Fischer (Washington); Robert Golden (Arlington, VA); Evelyn Gordon & Mark Jollife (Lambertville); S.C. & Dot Hendershot (Newton); Haim Loran (Millington); Brad Morris (Manorville, NY); Leif Myhre (Far Hills); Richard Ramos (Englishtown); Dr. John Simonton (Rye, NY); Ted & Lila Wainer (Rockaway); and George Winship (Cedar Grove).

In our next issue Alex Farnham will start a column detailing "new" New Jersey makers that are being found. If you have a N.J. signature that is unrecorded, or have any information about unrecorded makers, contact Alex at Box 365, RD 2, Stockton, NJ 08559.

### *Meet Your Dealers*

*The purpose of this column is NOT to evaluate dealers, but simply to present useful and interesting information about sources of tools.*

One of the most experienced tool dealers active today, Bud Brown started selling tools in 1971 at Hummer's Market in Adamstown, PA. As any of you who have made the pilgrimage to Adamstown know, it was one of the early hunting grounds for the flea market enthusiast. Renningers, the Black Angus, Shupp's Grove, Hummer's (now renamed Adams Antiques) and other markets are still going strong, with a wide variety of tools among the other flea market merchandise. It is a good place to begin a collection, and Bud helped many beginners.

With growing knowledge of the less common tools, the sort that are to be found only at the National auctions, Bud joined forces with Al Bates to bring the first nationally advertised tool auction to the West Coast. This was in San Diego, March 1986. Bates and Brown produced a mail auction and three more National auctions in Wilmington and New Castle, Delaware, and established a reputation as a major source of the less common tools. With Al's increasing involvement with E.A.I.A. as President and Executive Director, Bud carried on alone as Brown Auction Services with annual auctions in Morgantown, PA. His tenth Auction, scheduled for this October (29-30), graduated from "National" to "International", and promises to be the best yet.

His services to the tool fraternity include activity in E.A.I.A. (elected Director in June 1983). You may remember a visit to the Gruber Wagon works at an E.A.I.A. meeting which Bud arranged for. He has been a member of CRAFTS since 1979.

With an impressive knowledge of current tool prices, Bud has been involved in appraisals of collections for estates and donations. Certified by the major appraisal organizations and willing to cope with the governmental hassles involved, he is one of a vanishing breed.

Bud gave up his post at Hummer's four years ago under pressure of preparations for his auctions, but still deals in tools, by appointment, from a studio in his home in Temple, PA. If you have a serious interest in acquiring a rare tool, a call to 215-929-3445 might be worth while.

John Whelan

## Foreign Wooden Planes continued

by Jack Whelan

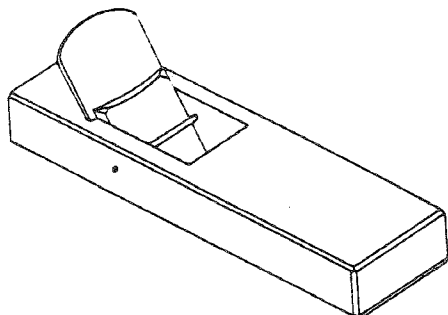

Figure 2. Japanese hand plane.

The same task is accomplished quite differently in Japan. The hira-kanna (Figure 2) is pulled, not pushed. The left hand grasps the blade between thumb and forefinger, with the other three fingers on the heel of the plane. (I use the names that would be applied to our planes: a Japanese would say the left hand is at the front of the plane.) This hand just pulls, and does not press down. The right hand holds the stock near the middle, usually with the forefinger in the throat, and provides the downward pressure as well as some pull. The same shape is used for jack and several grades of smooth plane. Working primarily with soft woods and using the plane as the final smoothing tool (sandpaper is looked down upon), the plane relies on a very fast stroke and a low pitch (below 40 degrees) for best smoothness.

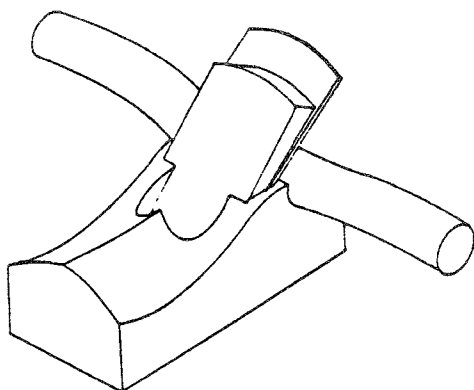

Figure 3. Chinese plane.

Chinese bench planes (Figure 3), contrary to some authorities, are not pulled, but are pushed. Their shape is closer to those of Japan than to our planes (Japan

learned about the plane from China). I have not been able to find any references in English on how their plane is held, and must rely on my own experiments. Palms on top of the side handles, thumbs below and forefingers pressing on top of the stock feels awkward at first, but soon produces good results. Finger pressure is high at the beginning of the cut, lessened as it progresses.

The Chinese style was adapted throughout southeast Asia and the East Indies. Many of these are fantastically carved to depict mythical animals, to help the plane to "chew the wood." The contrast in these various styles helps to clarify which aspects of plane design are essential to good performance, as distinguished from those representing equally good approaches to accomplishing the end. Planes of whatever style which perform well will have a mouth just wide enough to pass the thickest shaving expected, and a flat bottom which presses firmly on the wood being cut just in front of the cutting edge.

Turning to molding planes, the most reliable (but not infallible) diagnostic for a Continental or Asian molder is the absence of spring. Let's review what is meant by "spring." English and American planes which cut angled moldings are designed to be held with the stock at a sidewise angle, to put the sole of the plane parallel to the overall angle of the molding (scribed "spring marks" on the toe indicate the proper angle). This design avoids having sections of the cutting edge at a steep angle to the surface being formed. Our side bead planes are not sprung (the re-entrant cut of the quirk would be rough if they were), but most of our other molders are.

Planes other than English and American are almost never sprung. Some of our early planes, such as an ovolo made by Francis Nicholson in the early eighteenth century, are unsprung; so that we have tried this style and abandoned it. Continental makers were certainly aware of the use of spring, but never adapted it. One can only surmise that they found holding the planes at an angle more objectionable than taking a few more strokes to do the same job and keeping their blades sharper.

An exception to this generalization about spring is found in French and Japanese molders used to cut quarter-round and similar moldings on the edges of case pieces (as opposed to molding strips). These are often in the shape of a bench plane (shavings escape from the top) with the sole cut into a deep V-groove, having the molding profile in its center.

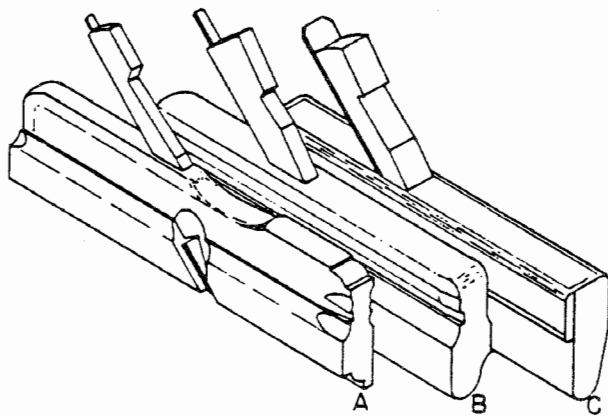

Figure 4. Continental molders.

Determining the country of origin of a molding plane is not a cut-and-dried process, but certain diagnostics may be helpful. Dutch molders almost invariably have a certain pattern of body decoration (see Figure 4 A), a shallow hollow in front of the wedge, an inset quarter round at front top and a chisel cut between two gouge cuts at the step. These are relatively easy to spot. German bodies (Figure 4 B) often run a groove above the step in the side. (The step marks the point at which our planes are narrowed at the top to provide a more comfortable hand-hold). French molders rarely have a step, but either keep the same body thickness for their full height, or (in later planes) have an open throat cut in the stock and covered over with an applied batten (Figure 4 C). The wedge finials may provide a clue; Figure 5 shows typical patterns. German and Austrian are often flat-topped, French slightly rounded. Both continue their wedge shape through the top of the finial, which is demarked only by two straight-line cuts. Dutch wedges are like the German, but break the wedge slope to slant backward more sharply.

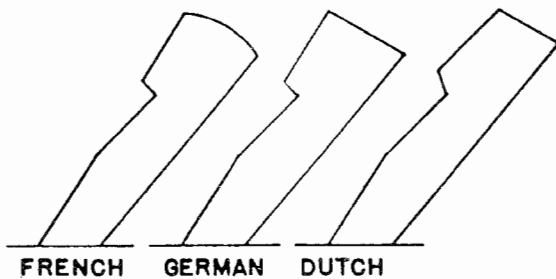
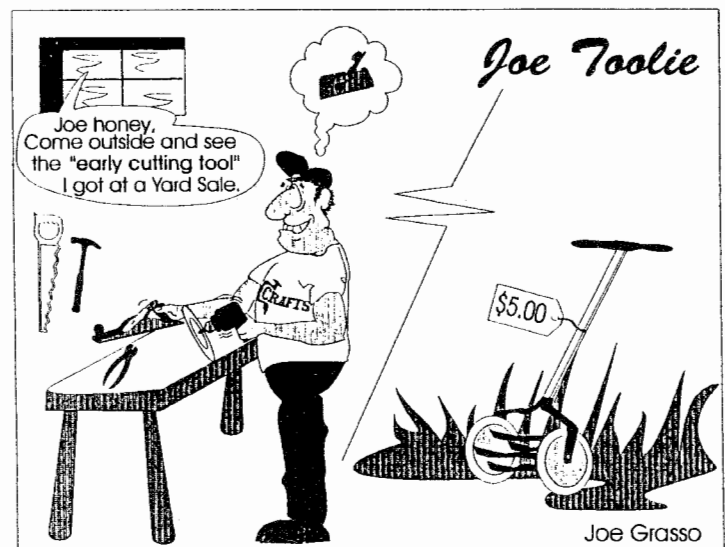

Figure 5. Continental wedges.

The Chinese molders I have seen are of two types. Some are in the general body shape of their bench planes, but without the transverse dowels. The blade is held in place by a wedge between it and a metal rod imbedded in the sides and crossing the throat. The wedge may be of wood, usually without finial, or of metal. Another type resembles the early French molders, having an open throat cut into the side of the stock.

The Japanese quarter-round type molders mentioned above often differ from Western practice in having cap irons, shaped to follow the contour of the cutting iron. They may have the front of the throat contoured to follow the molding contour, which facilitates passage of the shavings. They also used molders in the same general shape as ours, higher than wide, but these usually have rounded tops or have part of the top cut away behind the blade. Older tools may have handholds made by cutting a slot for the fingers through the top of the stock, and may have a wedge behind, rather than in front of, the blade. Rabbits and molding planes are also found which use no wedge: the iron is wedge-shaped and acts as its own wedge. All of these are pulled, not pushed.

We are beginning to see more foreign planes in the auctions, at the dealers and on the tail-gates. Don't dismiss them out of hand because they are "foreign." They will repay your inspection. But leave a few for me, won't you?



## Making Wooden Planes With Hand Tools

by Donald Kahn

Shortly after I started woodworking in the late 70's, I was introduced to handmade wooden planes by James Krenov, not personally, but through his book, "The Fine Art Of Cabinetmaking." He gives step-by-step clear and concise instructions. Krenov states that, "It is not an anybody-can-do-it type of thing," but I decided to plunge ahead anyway. All I could do was waste a few dollars worth of wood.

But, wait a minute. He's making them with power tools. I can't use power tools! I live in a high-rise apartment building surrounded by neighbors who would have me evicted for the slightest noise. So, it had to be "hand tools only." I was told that you couldn't make good wooden planes with hand tools; just too hard to do. Well, all planes in the 18th century, and a good part of the 19th century, were made with hand tools only. If they could do it, why couldn't a 20th century woodworker do it?

I followed Krenov's step-by-step instructions, and made my first wooden plane -- a smooth plane. I have to say it looked great, and even worked well. A jointer and a jack plane followed, and then a moving filletster and, shoulder plane.

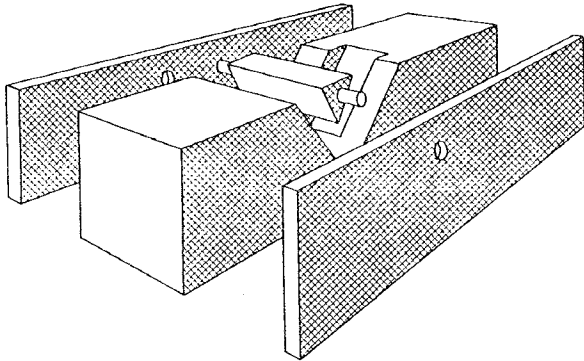

Laminated or sandwich body plane.

The first planes that I made were what we call the laminated type (see sketch above). It is relatively simple to make compared to the traditional type that I graduated to. Now I make bench planes in the traditional way, i.e. chopping the throat and mouth out of a single block of wood.

### Here's The Way I Do It Now

First, obtain a good iron. Whether it's an old or new iron, you'll still have to tune it up. An old iron must be cleaned up so there is no rust on any cutting edge. Whether old or new; you must lap the back of the iron to flatten it, grind a square edge, and then sharpen it. Sharpening is an art of its own, with most

people preferring their own special way.

Second, make a wedge blank that will match the slot that you will later make in the plane. This will have to be made from your design sketch, and be based upon the thickness and taper of the iron. You will need this blank to test the fit of the wedge slot as you make it. The wedge is finished after completing the throat.

Third, try and true a block of hardwood to the finished size of your plane. It's important to have opposite sides parallel to each other and square to their adjacent sides if you want an accurate throat. The grain of the wood should run-out towards the heel, and the growth rings should be convex to the sole (see sketch below).

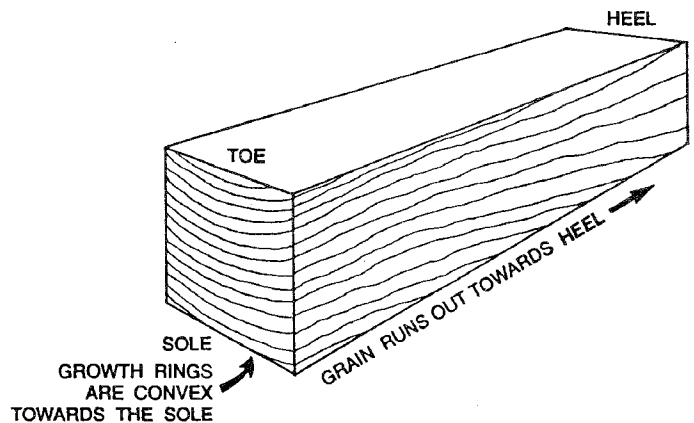

The choice of wood is up to you. Native hardwoods such as beech, apple and hard maple are fine (although few planes were made of maple). Tropical hardwoods such as rosewood or ebony are even better, if you can find or afford them in the thicknesses needed.

### Basic Cabinetmaker's Tools Are All You Need

Saws, benchplanes, chisels, and marking tools are the tools required. Well, one additional tool would be great to have: a planemaker's float. If you can't get one, a good mill file with safe (unserrated) edges will work almost as well. Antique planemaker's floats are rather rare, and I do not suggest using them. You can make a float or two yourself, but that's my next article. I made a set of four floats, along with a few bevels set at 12½°, 50°, 55° and 60° (I didn't make a 45° bevel because I don't make planes with that pitch). Most of my planes are made with their irons bedded at 50°.

## Laying Out the Throat and Mouth

An excellent booklet describing the layout and the cutting of the throat, wedge slots, and mouth is "How To Make Wooden Planes" by Perch and Lee. This booklet is a must for any first time attempt at planemaking. However, I recommend that you do not make the mouth opening 3/8" as they do, unless you have an exceptionally thick iron or are using a very low pitch. I find that if you wish to do fine work the opening should be much smaller. In fact, I make it so tight that the iron will not go through. In the final stages of tuning the plane, I open the mouth up with a detail file just enough to produce a very fine shaving that does not clog the throat.

After opening the mouth, flatten the sole on a strip of sandpaper (about 150 grit), on a surface that you know is flat, such as a 1/4" sheet of glass, or the top of a table saw.

Now, you can finish the wedge, and shape the body of the plane. You can chamfer the edges, and make a handle if needed. After all is right with the plane, and it is producing good shavings, oil it. On native hardwoods, boiled linseed oil works fine; on tropical hardwoods, *Watco Danish Finish* is best.

Using a tool that you made yourself adds satisfaction to the already exciting field of woodworking.

## Further Reading

Bourdeau, Robert; A Pair of Panel-Raising Planes, Fine Woodworking, p. 59, September/October, 1981.

Ellsworth, Timothy E., Hand Planes, Fine Woodworking, p. 22, Winter, 1975.

Krenov, James: The Fine Art Of Cabinetmaking, Litton Educational Publishing, Inc., 1977.

Perch, David G. and Lee, Leonard G., How To Make Wooden Planes, Lee Valley Tools Limited, 1981.

Pierce, Cecil E., Fifty Years A Planemaker And User, Monmouth Press, 1992.

Rodriguez, Mario, A Plane That's Fancy. American Woodworker, p. 18, May/June, 1992.



Planes made by author.

## Buy, Swap, & Sell

CRAFTS members only may have a free 5 line (40 word) ad that is primarily related to the exchange of tools or information. Each additional line (over 5) is \$1. Send to: Stuart Shippey, 251 Hillside Ave., Chatham, NJ 07928. All ads accepted on a space permitting basis. Print or type.

## WANTED

Mint condition or unusual SAWS. Brass backed or otherwise nice American back saws particularly desired. Also wanted, signed American SQUARES, mitre squares, and bevel squares. Lee Richmond, (703) 391-0074.

Needed for MUSEUM TINSMITH SHOP DISPLAY CHARCOAL BRAZIER iron "disk," probably 3 legs, less than 12" diameter. Wilma Sagurton, (201) 543-4724.

OHIO TOOL CO. WOOD PLANES all types, sizes. Hollows and rounds OK. Condition must be Good or better. No missing parts or repairs. Bob Howard, 5 Glenrich Dr., St. James, NY 11780-1610. (516) 724-6514.

STANLEY PLANES Nos. 4½H, 5½H, 10½C, 10¼C, 11½, 12¾, 87, 018, 019, 63, 80 S/C, 90A, 101½, 239½, 190W, 602C, 604½. Bill Hermanek, 31 Wildwood La., Smithtown, NY 11787. (516) 360-1216.

Two new collectors / users. All carpentry, blacksmithing, clocks and clock repair. Especially, moulding, match, low angle and standard block and bench planes. Usable Stanley #45, #55. Send list and prices to Mark Thompson, 94-03 Hollis Ct Blvd., Queens Village, NY 11428.

## FOR SALE

Meet the craftsman, the endangered species. Buy-Sell-Trade - Antique & Users Tools at the Lambertville, NJ Antique Market - Tables #56 Sundays Joseph Janiszewski.

ANTIQUe TOOL THEMES PRINTED ON T-SHIRTS, sweatshirts, mugs, totebags & aprons. Makes a great gift! Free catalog of antique toolwear products. The Matlin Group, Inc. PO Box 143, Wickatunk, NJ 07765-0143.

Stanley #0 level - rare 18" size \$20; #32 caliper rule \$15; 6" smoother \$15; L.Fox & Son ovolo \$15; Auburn quirked ogee & bevel \$30; D.Copeland quirked ogee & astragal \$30; Greenfield grecian ogee & fillet 2 7/8" wide \$50; Bonney combo pipe & monkey wrench \$15; Stanley #140 plane \$75. Herb Kean (201) 993-8374.

Sewing items & tools at the Garden State Exhibit Center, Somerset, NJ Aug. 28,29; at Tinicum Park, Erwinna, PA Sept. 11,12; at New Hope, PA firehouse Sept. 25,26. Look for Garrison House Antiques (908) 273-7709.

2" air dried beech - just right for plane making. Call Jim Rendi 689-4717 or write PO Box 67, Earlville, PA 19519. Want usable side rabbett plane.

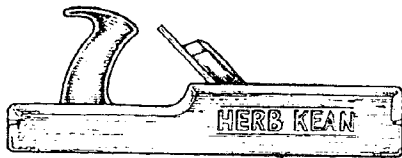

## Kean Kuttin's A Real Lemon

If anyone wanted to spend the time to analyze all the antique tools that were professionally produced, they might come up with a paradox something like this: the more ineffective a thing was, the more valuable it is today. Sure, that's an oversimplification, but the basis of this premise is rarity. If it's near useless, even those who were gullible enough to fall for the outrageous claims of the maker, will eventually bad-mouth the thing out of existence. Although rarity is not the only criterion for value, it is an important one.

So it was when I was given a humble looking wooden smooth plane to restore. It had a piece of the sole cut out just forward of the mouth. This is a common malady of planes repaired with sole inserts, as shrinkage sometimes causes the insert to fall out. So I looked at the nose to see if the maker was valuable enough to warrant restoration, but found no mark at all. If I was dealing with a beginner-collector, I would have told him to save the wedge and iron and throw the body away. (I can see the cringing of some readers just to think about throwing anything away.) But this was a collector who knew what he was doing, so I finally asked, "O.K., what's the secret here?" The "secret" was that this plane broke the rule of "maker's marks are always on the nose." On the heel was stamped: L.C. Ashley / Patented , Feb / 1856.

Who was Ashley, and what in the world was so special about a sole insert? At this point the owner of the plane whipped out the patent papers which described the plane in glorious detail, professing that it would cure everything from torn grain to tennis elbow. But the patent did solve the mystery of the cut-away sole. In part of that opening went an iron sole insert with a long flange that attached to a tongue-like wooden piece in the throat -- see *As Designed* sketch.

The inventor lauded his geometric perfection of all angles, etc., stating that the plane would maintain a perfect mouth opening even as the stock wore away. But looking at the plane I couldn't see what he was referring to, because there was no tongue-like piece to provide any angular control. The throat was clean -- see *As Found* sketch. Well almost clean. Closer examination showed an outline where the throat-piece used to be, and some hack marks that were made during its removal. In addition, it was evident that the sole had been cut into to provide a seat for the replacement wooden insert. The obvious questions came

quickly: why would anyone destroy such a "spectacular" idea, and why go through so much work to do it?

I suppose in those days it was cheaper to fix something (no matter how time consuming) rather than buy new. But what was the problem to start with? Only two possibilities came to mind: the plane was dropped and the iron piece (most likely a casting) cracked and was scrapped. Not being able to get another, or not wanting to spend the money, the owner modified the sole with a wooden insert. Why then did he cut away the throat-piece? A more likely explanation was that the throat-piece was clogging the chips and making it very difficult to remove them. In short, it was a poor design.

Proudly I handed back the plane and the patent papers, and gave him my evaluation, "No need to spend money fixing up this lemon." However, the other guy's "calculator" must have been active while I was expounding my theory, as he was now honestly excited. He explained that if this thing was as bad as I said, there probably wouldn't be many around today, in any condition; and if I made it like the patent papers it might be quite rare, even though restored. Embarrassed, I could only respond, "I knew that."

So I restored it the way Mr. L.C. Ashley designed it, and sure enough the chips clogged and were tough to remove. As I was grumbling about putting out a product with out testing it, my wife reminded me that many of her household items are near worthless because they were never tried by the people who were to use them. Her favorite expression for such a lemon is, "This must have been designed by a man." What she really means is that it must have been designed by someone who was not a homemaker.

This prompts me to the following conclusion: the plane patented by L.C. Ashley, Patent No. 14436, must have been designed by someone who was not a woodworker. I wonder how many others are like that?

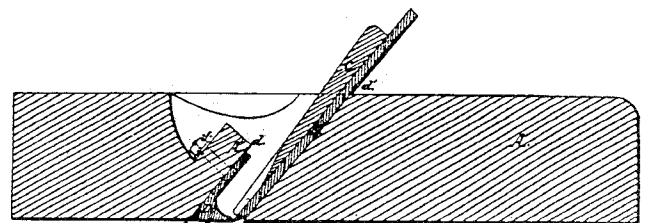

As Designed

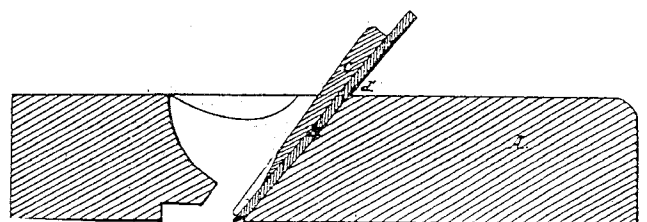

As Found



## On Identifying 18th Century American Wooden Planes by Emil Pollak

The best and perhaps only way to be certain that what you're looking at is an 18th century American wooden plane is to be holding an example imprinted by Francis Nicholson, Samuel Caruthers or any one of the handful of 18th century planemakers who were considerate enough to die before January 1, 1800. A plane made by Jo. Fuller or Aaron Smith or any of their contemporaries won't do, since their planemaking, although beginning in the 18th century, extended well into the early 19th.

Nevertheless, a planemaker's imprint can be very helpful. Therefore your first step is always to look at the upper front end (the toe) of the plane to see if there's a maker's mark stamped into what is called the maker's slot. This is where the planemaker's imprint will almost always be found, partly because of tradition, partly because the end grain took and held the imprint best. If there is a maker's imprint you can look it up in "Guide to American Wooden Planes and Their Makers," where you may find helpful information including working dates. If there is no maker imprint or the working dates are inconclusive, try the following:

1. Length of the plane. Generally the longer the molding plane, the earlier it is. Planes 9 7/8"-10" long probably date before the American Revolution; 9 5/8"-9 3/4" indicates the last quarter of the 18th century to the early 19th century. Planes are sometimes found less than 9 1/2" long, usually between 9 1/4"-9 3/8". These most often date from around 1800. American molding planes went to a standard 9 1/2" length during the second quarter of the 19th century.

2. The kind of wood used. Yellow birch usually means a New England origin and a plane made before 1800. Beech was used later in New England and both early and late in New York and Pennsylvania. Ebony, boxwood, rosewood, and *Iignum vitae* usually indicate a date well after 1800.

3. The style of the wedge (if it is original). Early wedges were highly individualized, reflecting the maker's aesthetic taste and the training he had received. Fig. 1 shows some of the different styles found in 18th century molding planes. The early Jo. Fuller wedge is relieved (cut away) in the back behind the finial. The relieved wedge is found frequently in late 18th century southeastern Massachusetts planes. The Sleeper wedge originated by John Sleeper (1754-1834) of Newburyport, MA, was subsequently adopted by other planemakers in that area. Francis Nicholson, the first documented American planemaker, who worked before

the American revolution, used a wedge outline sometimes called the "Wrentham" type wedge (named after his hometown of Wrentham, MA). This style was adopted by some of his contemporaries in that area. Eighteenth century wedges used in bench planes, panel raisers and cornice planes most often have rounded tops rather than the straight angular style of the 19c.

4. Chamfering. What kind of chamfering does the plane have along its top, and down the sides of its toe and heel? Wide flat chamfers (3/8"-1/2") usually indicate a plane made before 1800. Narrower flat chamfers (3/16"-1/4") indicate circa 1800. Wide rounded chamfers (1/4"-3/8") usually appear on planes made between 1800 and 1830. After that, narrow rounded chamfers (1/8" x 1/4") or no chamfers became the standard.

5. The Plane Iron. Eighteenth century plane irons were made of wrought iron with a laid on steel cutting area. Heavy use requiring repeated sharpening could use up the cutting area and require a replacement iron. Molding planes, particularly complex molders, were generally less heavily used than bench planes; and their irons, therefore, were less frequently replaced and are more likely to be original. Still the case of substitution and need for replacement makes the use of the plane iron as evidence of age rather tricky. Planes originating in or near the major cities such as New York and Philadelphia often used irons imported from England, signed by makers such as Newbould, Green and Hildick. However, working dates for these early makers have still not been fully established. Eighteenth century planemakers in the more rural areas often used irons made by local blacksmiths which were seldom signed. Eighteenth century irons used in bench planes, panel raisers and cornice planes usually have rounded tops that matched their wedges.

6. Number of Owners' Marks. The number of plane owners' marks on a plane can sometimes be helpful. Owners frequently marked their planes with their initials or names for identification. Planes often passed from generation to generation or were sold after probate to other woodworkers and marked with the new owner's name or initials. While there are some very old planes that have no owners' marks and others only one, generally speaking, a plane with three or more different owners' marks may well have been made before 1800. It is also sometimes possible to find information on a plane's owner. Not only does this help in dating the plane, but also greatly increases the interest of the tool.

7. Special Characteristics of 18th century plane types.

a) Plow planes having riveted skates are early, usually before 1800; those with screwed on skates after 1800. Slide arms secured by thumbscrews were used on the very early plows and continued to be used until around 1820. Screw arm plows appeared after 1800, most frequently after 1820-30. Slide arms locked by wedges were used over the entire period. Eighteenth century plow planes were unhandled. Handled plows appeared in the early 19th century. The Yankee plow, particularly when made of yellow birch, 9 3/4- 10" long, and with a riveted skate was almost always 18th century.

b) Eighteenth century sash planes are most often of the single iron and occasionally the double iron solid body variety. Split body types with adjustable screw or screw arms are 19th century.

c) Plane handles on 18th century planes have two special characteristics. One is their shape as shown in Fig. 2; the other, location of the handle on the plane's stock. Off center placement is a characteristic of the earlier planes; the more, the earlier.

d) Bench Planes. Because of the heavy use bench planes received, very few 18c. bench planes have survived. They are actually quite rare, and the presumption should be that a bench plane is 19c. unless there is strong evidence to the contrary.

e) Eighteenth century panel raisers are narrower than those made in the 19c. Generally their irons will be 2"-2 1/4" wide versus 2-1/2" and up in the 19c. examples. Eighteenth century examples will usually have integral fences; 19th century, adjustable fences.

8. Wedge Slot. Another characteristic of 18th century New England planemakers was the practice of chamfering the front edge of the wedge slot, presumably to prevent splitting the plane stock when the wedge was driven in.

One caution: changes in plane styles appeared first in major towns and cities and then, sometimes with a considerable time lag, in the hinterland. Thus, planes with wide flat chamfers and a length of 9 3/4-10", (both 18th century characteristics) were still being made in rural central Pennsylvania and New England during the early 19th century.

No matter what you are collecting, insight and judgment come with experience. There are no short cuts. One must read the literature, question and listen to more experienced collectors and look at and handle as many examples as possible. The foregoing are some basic guidelines that can be helpful in estimating the age of a plane. There will always be exceptions, which, of course, is part of the fun.

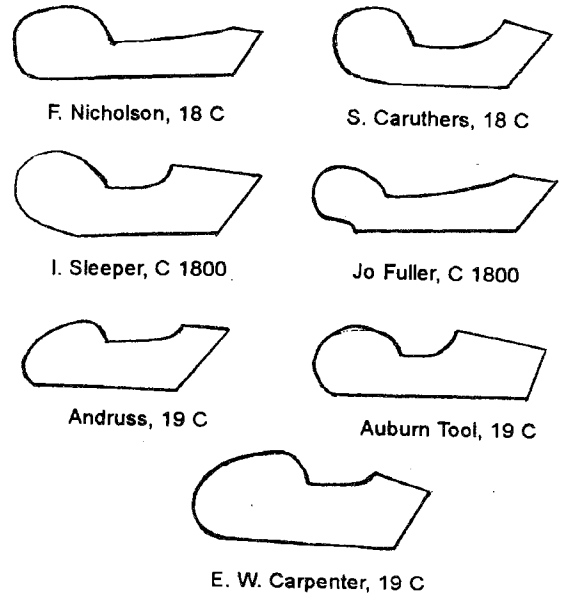

Molding Planes above

Bench Planes below

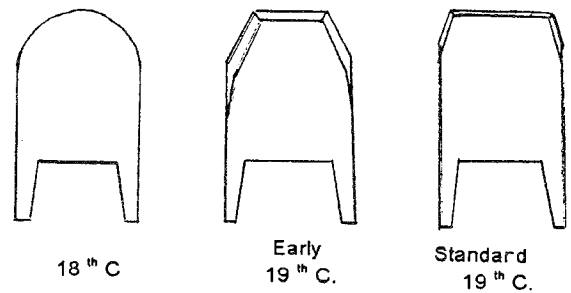

Figure 1. Wedges

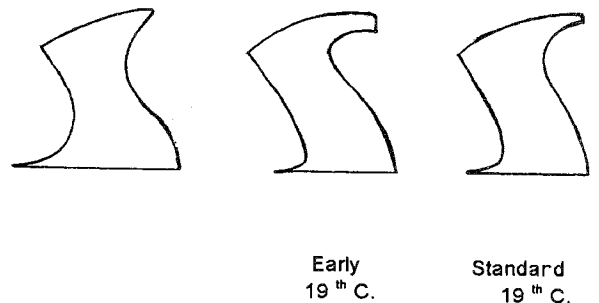
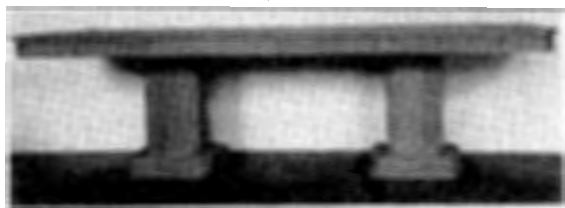

Figure 2. Open Handles

## The Old Way Versus The New Way by Dominic Micalizzi

The *TOOLSHED*'s roving reporter, Herb Kean, requested that I give him a call when I was working on an interesting piece of furniture. I had three pieces in work at the time, and called him when they were near completion. One was a Home Office with a front that dropped down and legs that flipped out, to form a desk. The second was a nine foot mahogany Dining Table which opens to fourteen feet; and the third was a burl walnut Entertainment Center. After examining and discussing the pieces with me, Herb thought the table was more classic and would make the best article. I pointed out that there weren't many hand tools used in the production of these pieces. "Think of something," he replied. "Write on the process of making custom furniture."

It wasn't until Herb left that I realized that I had been hoodwinked into writing an article. I thought the roving reporter did the writing! Be that as it may, I thought of something. I would write on Where, Why, and How the use of hand tools were replaced by power tools in the making of this table. This may seem contrary to antique tool interest, but it is closer to the way that furniture is made today. Most people realize that both the Old Way and the New Way produce beautiful results when done by true craftsmen.



After reviewing the problems with the client, eg: excessive length, weight, stability, and availability of

extra length slides, we settled on the design. Since there also would be a ten foot Breakfront, I decided to use elements from it on the table's pedestals, thus giving better continuity between the pieces.

For the top, I used one inch thick "Honduras" mahogany veneered plywood, book-matched. This eliminated hand planes for the jointing and surfacing of a solid-board top, as was done in the days of old. After the top was cut to size on the table saw, the molding for the edges was cut on a shaper, doing away with hand saws and molding planes. The molding was mitred on the table saw, rather than a miter box and back saw. It was glued and tacked on the plywood with a nail-gun instead of a hammer and nailset.

Next was the drilling for the alignment pins that matched the tabletop sections. Up to a few months ago, I would mark off each hole using a marking gage and try square, and drill with a brace and bit. Now I use an air-powered hand jig of my own design. It allows me to drill both tabletop sections from one jig setting, giving me perfectly matched alignment holes. The pedestals, and the assembly of the table proceeded in much the same manner. The only hand tools used were a dovetail saw (to miter the beading on the pedestals) and a bullnose rabbet plane (to clean up the molding).

The metal tracking slides proved to be no problem since I buy them from a company that will make them to any size. In fact, since the tracks had equalizers, one person could easily open or close the table alone. The tracks were installed with an electric drill and, a power-screwdriver.

After sanding, a filler was rubbed on, then off, and was allowed to dry overnight. Stain was applied that matched one of the client's chairs, and also was allowed to dry overnight. The table was finished using spray lacquer, which was sanded after each coat.

Not using hand tools on the table doesn't mean I'm trying to eliminate them. There was a time when I wouldn't use anything that didn't have an electric cord attached to it. It wasn't until I became a tool collector that I started using hand tools at all. Now I feel more connected to the work when using a plane, as opposed to a noisy belt sander.

I am presently working on a hand dovetailed toy chest that will be inlaid with a carved ballon and a locomotive (done in relief), using various colorful woods. This will require the use of chisels, saws, planes, scrapers, and the most wondrous tool of all -- imagination. Who knows, maybe I'll march magnificently backwards to the Old Way!

## WILLY TELLUS WHATSIT

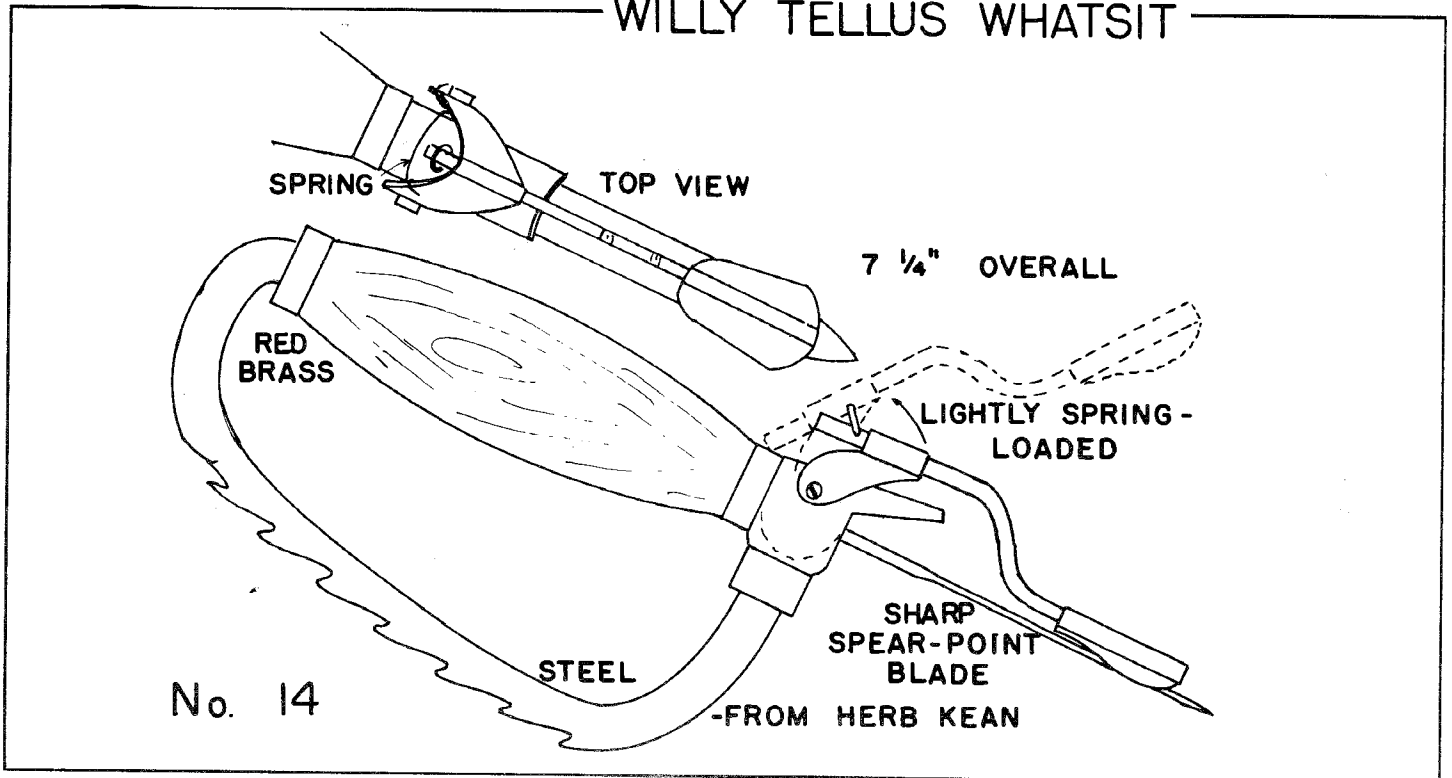

### Letters Received

I feel that I have the answer to the "Whatsit" shown in the June 1993 Toolshed (the same one that appeared in the June 1958 Chronicle of the E.A.I.A.). Strange as it seems, I have an old ice cream sandwich dipper, by Mayer Mfg. Co. of Chicago, that appears, to my eye, to very closely resemble the sketch shown in the Toolshed and which looks practically identical to the actual photograph of the device, shown in Fig. 3 in the 1958 Chronicle.

As is the case with many "Whatsits," I don't believe the one shown is complete, since it lacks the rectangular metal box-like encasement, which mine has. This encasement is attached to the fixed plate on the device and acts to form the ice cream sandwich shape when dipped into a bulk container of the frozen material. The moveable plate then serves as a follower to press the cream out of the encasement. As I recall, these "tools" were used back in the 1920's & 30's to serve ice cream sandwiches prior to the advent of pre-packaging.

Donald Werley, Allentown, Pa.

Whatsit #13 in the June Toolshed was solved in no time flat by my wife. It is the moving section of an incomplete ice cream slice maker. Missing is the semi-circular encloser that you push into a container of ice cream. The ice cream slice is ejected by pushing on the thumb lever. We have one hanging in our kitchen not far from where the Whatsit article was read by my wife. A picture of the complete slice maker is enclosed, taken from Linda Campbell Franklin's book, 300 Years of Kitchen Collectibles. Maybe the column should be titled "Willheshe Tellus Whatsit!"

Ray Hunt, Yorktown Hgts., N.Y.

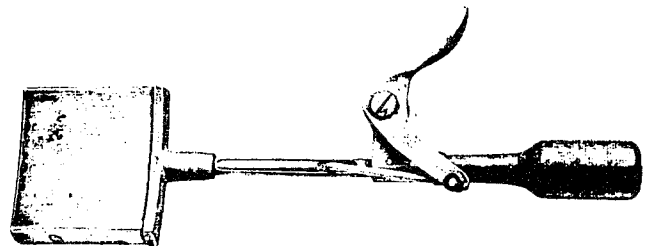
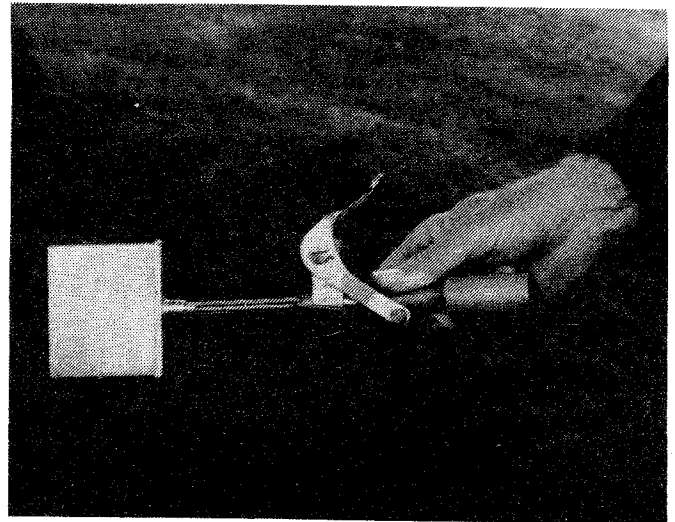

**Ice Cream Disher.**  
Nickel plated brass with wood handle. This one makes slices for pie a la mode or ice cream sandwiches. c. 1930s. 12½" long.